



P-Pal Co.Ltd. (Taiwan)  
Jiangsu Zhongsheng Leisure Products Co. Ltd. (China)



# (Company profile)



## Company profile:

P-Pal co.ltd. (Taiwan) is an investment company which has an investment in Jiangsu zhongsheng leisure products Co.Ltd (China) which is located in Huaian, Jiangsu province----the beloved premier Zhou Enlai's hometown.

Our company is a professional manufacturer of leisure furniture, which is solid in technical force and rich in outstanding talents and comprehensive technical staff. Our company has always pursued the principle ---“Quality is the life, Custom is the god” since our establishment. which we produce Outdoor and indoor use tables and chairs etc. ,have good quality and superior service, as a result of which, our products are widely recognized and trusted by our clients.



# (Company Installation)



## Company installation:

Our company has a great many servo injection molding machines ranging from 100 tons to 1200 tons, the latest gas assisted molding equipment. many sets of automatic tube processing equipment and a full set of automatic spraying equipment. And we also set up our own lab testing center.

## Company' s products' design, and development features:

Our company focuses on designing, developing and manufacturing newly multi-functional leisure products suitable for both indoor and outdoor use., through which, we provide fashionable, environmental-friendly, portable, durable, recyclable products for our domestic and foreign customers. Our products are suitable for various occasions. They are top choices for home, office, exhibition, hotel and public places etc.



30,000 square meters



# (Design & Development)



We have been dedicated for years to the development, designing and manufacture of ecotype multifunctional leisure products suitable for both indoor and outdoor uses.

Our Italian designers focus on the idea of low-carbon, environment protection, energy-saving and multifunction to create fashionable, environment-friendly, convenient and durable products for both home and abroad consumers.

All series of products are characterized with engineering plastic products features like resistance to acid and base, and being easy to clean. Besides, they are inflaming retarding, water-proof, foldable, and convenient to carry and store, which makes them a superior choice for houses, offices, exhibitions, hotels, public leisure places, etc.

Our products are sold all over the world, and win reputation from both home and abroad customers for our superior quality and sincere service.



# (Company certification)



## Our Strengths

We have already passed certifications as ISO9001, ISO14000 and CE etc. and have several independent intellectual properties. We are one of the strongly recommended enterprises by The Economic & Trade Commission of Huai'an City.

ISO 9001

**Certificate of Approval**  
 Certificate No.: 10116016437805  
**Awarded to**  
**Jiangsu Zhongsheng Leisure Products CO.,LTD.**  
Organization Code Certificate No.: Unified Social Credit Code 91320831939746787Y  
 Registered Add: No.77, Shuangrong Avenue, Huzhou Economic Development Area, Jiangsu Province 222200, China  
 Office Add: No.18, Hongqiang Road, Huai'an Industrial Area, Huai'an District, Huai'an City, Jiangsu Province, China  
 Postcode: 223229  
 Production Add: No.18, Hongqiang Road, Huai'an Industrial Area, Huai'an District, Huai'an City, Jiangsu Province, China  
 Postcode: 223229

*Beijing ZhongLian TianRun Certification Center (ZLTR) certify that the Quality Management System of the above organization has been assessed and found to be in accordance with the requirements of the standard:*  
**ISO 9001: 2008**

**SCOPE OF CERTIFICATION/REGISTRATION**  
**The production of folding tables and chairs**

This certificate is made valid when used with certification scopes and the requirements of applicable laws and regulations. These requirements include, but are not limited to, administrative permits, scopes of qualifications, and CCC requirements.  
 Subject to operation conditions in requirements conformity with Quality Management System.  
 This Certificate is valid for a period of three years only.  
 Date from: Aug 15th, 2016 To: Sep 14th, 2018  
 Date of Trade/Jun 19th, 2017  
 The effectiveness of this Certificate shall be Validated by periodic surveillance audit of ZLTR for maintenance.  
 The time limit of the certificate is to Jun 6th, 2018, please conducting the surveillance or re-certification assessment before Jun 6th, 2018. If the assessment is overdue, the certificate is invalid.  
 Information of this certificate can be found on the official website of Beijing ZhongLian TianRun Certification Center (http://www.zltr.com.cn)

**Beijing ZhongLiantianrun Certification Center**  
Room 2202, 22nd Floor, 2nd Unit, Block 1, No. 4 Yueli Street, Changyang District, Beijing, P.R. China 100102

ISO 9001

ISO 14001

**Certificate of Environment Management System**  
 Certificate No.: 1011622274805  
**Awarded to**  
**Jiangsu Zhongsheng Leisure Products CO.,LTD.**  
Organization Code Certificate No.: Unified Social Credit Code 91320831939746787Y  
 Registered Add: No.77, Shuangrong Avenue, Huzhou Economic Development Area, Jiangsu Province 222200, China  
 Office Add: No.18, Hongqiang Road, Huai'an Industrial Area, Huai'an District, Huai'an City, Jiangsu Province, China  
 Postcode: 223229  
 Production Add: No.18, Hongqiang Road, Huai'an Industrial Area, Huai'an District, Huai'an City, Jiangsu Province, China  
 Postcode: 223229

*Beijing ZhongLian TianRun Certification Center (ZLTR) certify that the Environment Management System of the above organization has been assessed and found to be in accordance with the requirements of the standard:*  
**ISO 14001: 2004**

**SCOPE OF CERTIFICATION/REGISTRATION**  
**the environmental management activities involved by Sales of folding tables and chairs and places**

This certificate is made valid when used with certification scopes and the requirements of applicable laws and regulations. These requirements include, but are not limited to, administrative permits, scopes of qualifications, and CCC requirements.  
 Subject to operation conditions in requirements conformity with Environment Management System.  
 This Certificate is valid for a period of three years only.  
 Date from: Aug 15th, 2016 To: Sep 14th, 2018  
 The effectiveness of this Certificate shall be Validated by periodic surveillance audit of ZLTR for maintenance.  
 The time limit of the certificate is to Jun 7th, 2018, please conducting the surveillance or re-certification assessment before Jun 7th, 2018. If the assessment is overdue, the certificate is invalid.  
 Information of this certificate can be found on the official website of Beijing ZhongLian TianRun Certification Center (http://www.zltr.com.cn)

**Beijing ZhongLiantianrun Certification Center**  
Room 2202, 22nd Floor, 2nd Unit, Block 1, No. 4 Yueli Street, Changyang District, Beijing, P.R. China 100102

ISO 14001

OHSAS 18001

**Certificate of Occupational Health and Safety Management System**  
 Certificate No.: 10116116187805  
**Awarded to**  
**Jiangsu Zhongsheng Leisure Products CO.,LTD.**  
Organization Code Certificate No.: Unified Social Credit Code 91320831939746787Y  
 Registered Add: No.77, Shuangrong Avenue, Huzhou Economic Development Area, Jiangsu Province 222200, China  
 Office Add: No.18, Hongqiang Road, Huai'an Industrial Area, Huai'an District, Huai'an City, Jiangsu Province, China  
 Postcode: 223229  
 Production Add: No.18, Hongqiang Road, Huai'an Industrial Area, Huai'an District, Huai'an City, Jiangsu Province, China  
 Postcode: 223229

*Beijing ZhongLian TianRun Certification Center (ZLTR) certify that the Occupational health and safety Management System of the above organization has been assessed and found to be in accordance with the requirements of the standard:*  
**OHSAS 18001: 2007**

**SCOPE OF CERTIFICATION/REGISTRATION**  
**the occupational health and safety management activities involved by the production of folding tables and chairs and places**

This certificate is made valid when used with certification scopes and the requirements of applicable laws and regulations. These requirements include, but are not limited to, administrative permits, scopes of qualifications, and CCC requirements.  
 Subject to operation conditions in requirements conformity with Occupational health and safety Management System.  
 This Certificate is valid for a period of three years only.  
 Date from: Aug 15th, 2016 To: Aug 14th, 2019  
 Date of Trade/Jun 19th, 2017  
 The effectiveness of this Certificate shall be Validated by periodic surveillance audit of ZLTR for maintenance.  
 The time limit of the certificate is to Jun 6th, 2018, please conducting the surveillance or re-certification assessment before Jun 6th, 2018. If the assessment is overdue, the certificate is invalid.  
 Information of this certificate can be found on the official website of Beijing ZhongLian TianRun Certification Center (http://www.zltr.com.cn)

**Beijing ZhongLiantianrun Certification Center**  
Room 2202, 22nd Floor, 2nd Unit, Block 1, No. 4 Yueli Street, Changyang District, Beijing, P.R. China 100102

OHSAS 18001



# (Company certification)



## CERTIFICATES OF INDEPENDENT INTELLECTUAL PROPERTY

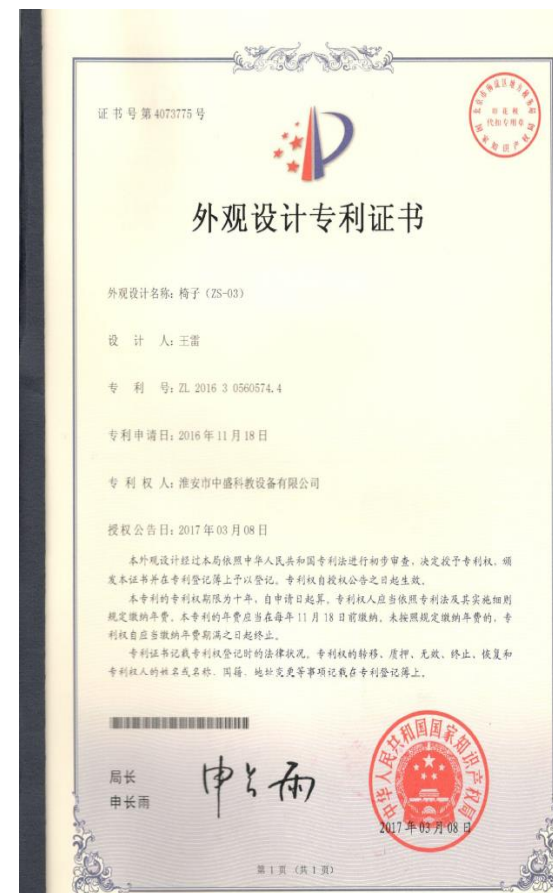
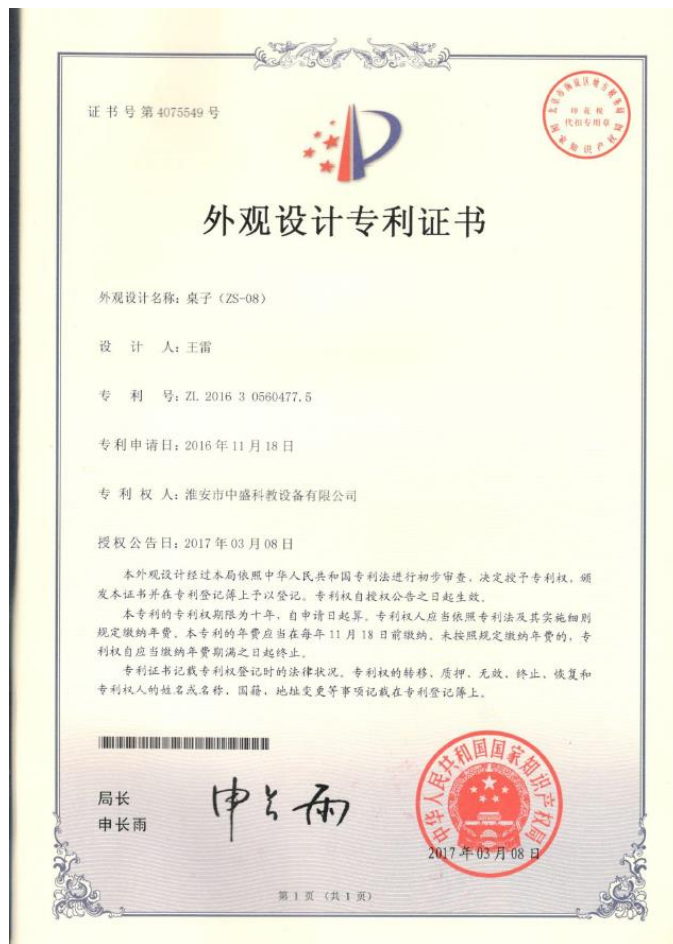

# (Company certification)



## Test report

Products Successfully by the third party inspection agency , Test accord with Europe and the United States test standard

**Intertek**  
Test Report

Number: SHAH0032676

Date: 06 Jan, 2016

Applicant: HUANAN ZHONGSHENG TEACHING EQUIPMENT CO.LTD  
NO.8 HUANGSHAN ROAD, SHIHE INDUSTRIAL ZONE, HUANAN DISTRICT, HUANAN CITY, JIANGSU PROVINCE, CHINA  
Attn: JERRY FAN

Sample Description:  
One (1) group of submitted sample said to be : Chair.  
Item Name : ZS-Y101

Tests Conducted:  
As requested by the applicant, for details refer to attached page(s).

Conclusion	Standard	Result
Tested samples Submitted sample	EN 581-1:2006 outdoors furniture -seating and table for camping, domestic and contract use - part 1: general safety requirements	Pass
	EN 581-1:2015 outdoors furniture - seating and table for camping, domestic and contract use - part 2: mechanical safety requirements and test methods for seating	Pass
	Excluding - clause 7-instruction for use	

To be continued

Authorized By:  
For Intertek Testing Services Ltd., Shanghai

*Leo Shi*

Leo Shi  
General Manager

Intertek Testing Services Ltd., Shanghai  
Block 8, Jinyang Business Square, No.821 Yixian Road, Shanghai, China 200233  
上海外高桥保税区耀华路821号  
Intertek Testing Services Ltd. 200233  
Telephone: +86 21 6321 6985 Fax: +86 21 6321 6740  
www.intertek.com www.intertek.com.cn

Page 1 of 4

**Intertek**  
Test Report

Number: SHAH0070575

Date: 27 Jul, 2016

Applicant: HUANAN ZHONGSHENG TEACHING EQUIPMENT CO.LTD  
NO.8 HUANGSHAN ROAD, SHIHE INDUSTRIAL ZONE, HUANAN DISTRICT, HUANAN CITY, JIANGSU PROVINCE, CHINA  
Attn: JERRY FAN

Sample Description:  
One (1) group of submitted sample said to be : Folding Chair  
Item Name : Folding Chair  
Item No : ZS-Y102  
Quantity : 1  
Country Of Origin : China

Tests Conducted:  
As requested by the applicant, for details refer to attached page(s).

Conclusion	Standard	Result
Tested samples Submitted sample	EN 581-1:2006 outdoors furniture -seating and table for camping, domestic and contract use - part 1: general safety requirements	Pass
	EN 581-1:2015 outdoors furniture - seating and tables for camping, domestic and contract use - part 2: mechanical safety requirements and test methods for seating	Pass
	Excluding - clause 8-instruction for use	

To be continued

Authorized By:  
For Intertek Testing Services Ltd., Shanghai

*Leo Shi*

Leo Shi  
General Manager

Intertek Testing Services Ltd., Shanghai  
Block 8, Jinyang Business Square, No.821 Yixian Road, Shanghai, China 200233  
上海外高桥保税区耀华路821号  
Intertek Testing Services Ltd. 200233  
Telephone: +86 21 6321 6985 Fax: +86 21 6321 6740  
www.intertek.com www.intertek.com.cn

Page 1 of 4

**Intertek**  
Test Report

Number: SHAH0373555

Date: 01 Nov, 2016

Applicant: HUANAN ZHONGSHENG TEACHING EQUIPMENT CO.LTD  
NO.8 HUANGSHAN ROAD, SHIHE INDUSTRIAL ZONE, HUANAN DISTRICT, HUANAN CITY, JIANGSU PROVINCE, CHINA  
Attn: JERRY FAN

Sample Description:  
One (1) Group of Submitted Sample Said To Be: Plastic Injection Chair  
Item Name : PLASTIC INJECTION CHAIR  
Item No : ZS-Y201  
Supplier Item No : ZS-Y201  
Pc No. : 5734048  
Vendor : HUANAN ZHONGSHENG TEACHING EQUIPMENT  
Buyer : Rona  
Goods Exported To : Canada  
Country Of Origin : China  
Initial Test : Yes [X]  
Repeat : Yes [X]  
Previous Report No. : /

Tests Conducted:  
As requested by the applicant, for details refer to attached page(s).

Conclusion	Standard	Result
Tested samples Submitted sample	Test protocol for Chair / Rocker / Glider / Loveseat / Sofa (RCN-43037-01, Version: 6)	Pass

To be Continued

Authorized By:  
For Intertek Testing Services Ltd., Shanghai

*Leo Shi*

Leo Shi  
General Manager

Intertek Testing Services Ltd., Shanghai  
Block 8, Jinyang Business Square, No.821 Yixian Road, Shanghai, China 200233  
上海外高桥保税区耀华路821号  
Intertek Testing Services Ltd. 200233  
Telephone: +86 21 6321 6985 Fax: +86 21 6321 6740  
www.intertek.com www.intertek.com.cn

Page 1 of 9

**Intertek**  
Test Report

Number: SHAH00774702

Date: 23 Feb, 2017

Applicant: HUANAN ZHONGSHENG TEACHING EQUIPMENT CO.LTD  
NO.8 HUANGSHAN ROAD, SHIHE INDUSTRIAL ZONE, HUANAN DISTRICT, HUANAN CITY, JIANGSU PROVINCE, CHINA  
Attn: JERRY FAN

Sample Description:  
One (1) group of submitted sample said to be : Plastic chair  
Item Name : Plastic chair  
Style No. : ZS-Y201  
Buyer : FLUKA DISSENY,S.A.U.  
Goods Exported To : Europe  
Country Of Origin : China

Tests Conducted:  
As requested by the applicant, for details refer to attached page(s).

Conclusion	Standard	Result
Tested samples Submitted sample	EN 581-1:2006 outdoors furniture -seating and table for camping, domestic and contract use - part 1: general safety requirements	Pass
	EN 581-1:2015 outdoors furniture - seating and table for camping, domestic and contract use - part 2: mechanical safety requirements and test methods for seating	Pass
	Excluding - clause 8-instruction for use	

To be continued

Authorized By:  
For Intertek Testing Services Ltd., Shanghai

*Leo Shi*

Leo Shi  
General Manager

Intertek Testing Services Ltd., Shanghai  
Block 8, Jinyang Business Square, No.821 Yixian Road, Shanghai, China 200233  
上海外高桥保税区耀华路821号  
Intertek Testing Services Ltd. 200233  
Telephone: +86 21 6321 6985 Fax: +86 21 6321 6740  
www.intertek.com www.intertek.com.cn

Page 1 of 4



# Injection Mold vs. Blow Molded



## Injection Molded

## Blow Molded

Cut-Off View

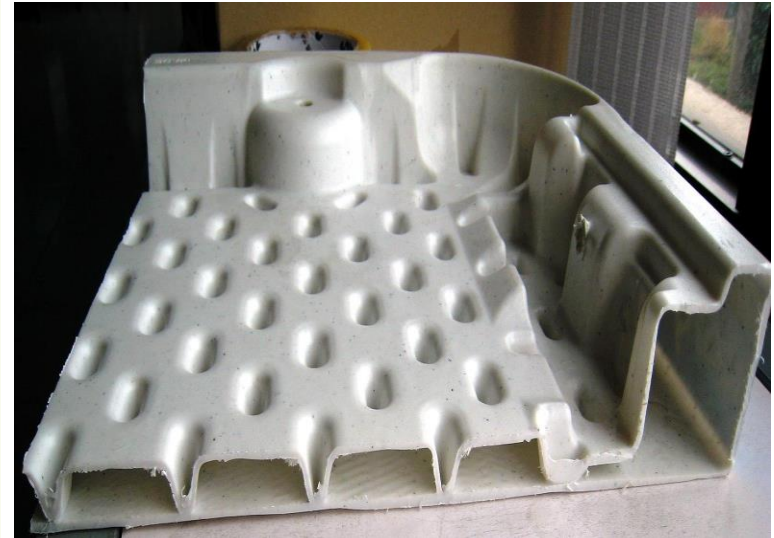

Molded Process

After the mold tooling is closed, inside of mold is near vacuum so the melted resin is injected into the tooling to get the product shaped. This process must be assisted with high pressure.

After the mold tooling is closed, the melted resin flows into the tooling, then “blow” with hot air to make the products expanded into its shape. By this process, there need not pressure.

Material

**Polypropylene (PP)**

**Polyethylene (PE)**





# Injection Mold vs. Blow Molded

## Injection Molded

## Blow Molded



### Advantages in Injection Molded

**High density:** Due to its molded process and one layer structure, so it's more impact resistant: when dropped onto ground, there'll be no deformation.

**Short cycle time:** Due to its molded process, the cooling system can be added inside the tooling. Therefore, at production, products can be cooled to save cycling time so capacity is greater.

**IP Issue:** Will not be involved in Intellectual Property (patent) problem

### Disadvantages in Injection Molded

**Market share:** As it is a new process for folding table production, few customers know about this technology.

**Investment high:** Due to the complicated process, the equipment and tooling costs are much more higher.

**Low density:** Due to its molded process and two layer hollow structure, so it's less impact resistant: when dropped onto ground, the corner will be broken.

**Long cycle time:** Due to its molded process, the products have to be cooled down naturally, so the unit cycling time is much more longer than injection molded, which means less capacity

**IP Issue:** Will be involved in IP problem: being sued

**Market Share:** For years blow molded table exist in market so all customers know this process.

**Investment low:** The equipment and tooling costs are much less so it's affordable by most investor.



# (Our Goals)



## 1. Planning for 2018:

- 1) regulation of production and sales management
- 2) automatization of facilities
- 3) effective and appropriate employee allocation
- 4) further improvement of system and criterions
- 5) annual production value of over 50,000,000 CNY

## 2. Planning for 2019 : to achieve

- 1) leading position in the industry regarding product quality
- 2) reduced energy consumption with automatization technique, based on high product quality
- 3) initial formation of unique corporate culture
- 4) basically appropriate allocation of facilities and other resources
- 5) annual production value of over 70,000,000 CNY

## 3. Planning for 2020 : to achieve

- 1) higher level of production capacity and quality
- 2) formation of good corporate culture
- 3) independent innovation, development and production of energy-saving and environment-friendly products
- 4) service and dedication to the society
- 5) annual production value of over 90,000,000 CNY



# (Organization Chart)

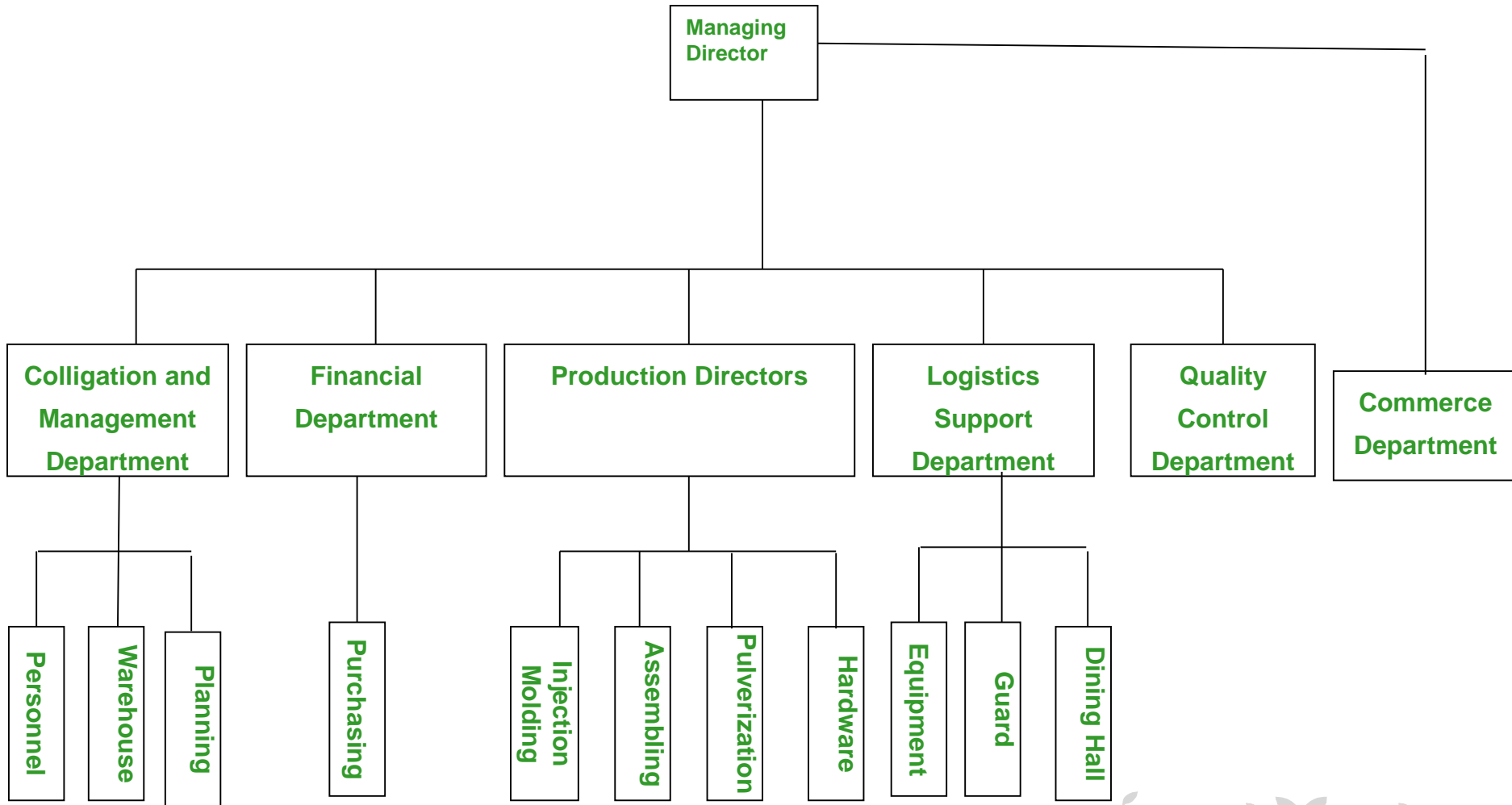

# (Main Customer)



ΚΟΥΤΣΟΘΑΝΑΣΗΣ *furniture*



# ITEM NO: ZS- FH122( 4FT) Folding in half table



**. Material :**

PP injection molding  
Steel frame Powder coated

**. Packing :** 1pc/ctn

**. Loading :** 752pcs/1619pcs/1908pcs  
( 20'GP/40'GP/40'HQ)

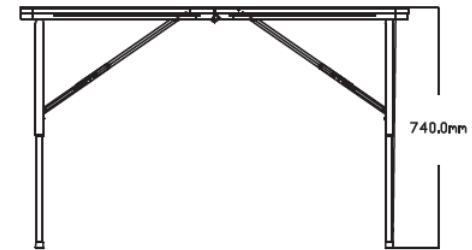

Available colors for plastic parts

White      Black



Available colors for metal parts

Gery      Dark Grey

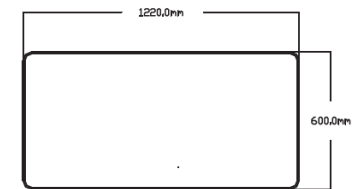

# ITEM NO: ZS- FH183- Z( 6FT) Folding in half table



## . Material :

PP injection  
Steel frame Powder coated

. Packing : 1pc/ctn

. Loading : pcs/pcs/pcs  
( 20'GP/40'GP/40'HQ)



Available colors for plastic parts

White      Black

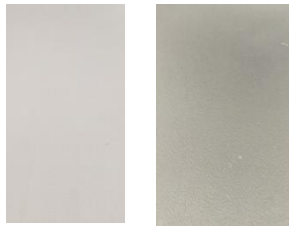

Available colors for metal parts

Gery      Dark Grey



# ITEM NO: ZS-R80 Folding table



## . Material :

PP injection molding  
Steel frame Powder coated

. Packing : 1pc/ctn

. Loading : 606pcs/1304pcs/1537pcs  
( 20'GP/40'GP/40'HQ)

Available colors for plastic parts

White      Black

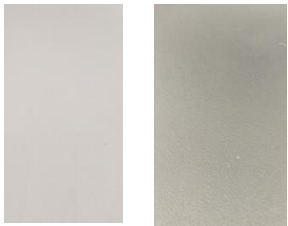

Available colors for metal parts

Gery      Dark Grey

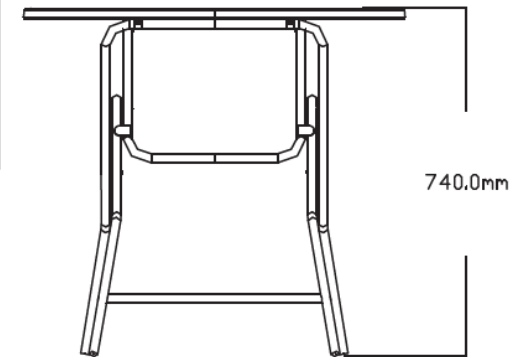
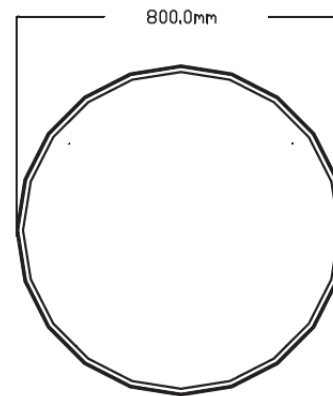

# ITEM NO: AT30-Z Folding tray table



## . Material :

PP injection  
Steel frame Powder coated

. Packing : 1pc/ctn

. Loading : pcs/pcs/pcs  
( 20'GP/40'GP/40'HQ)

Available colors for plastic parts

White      Black

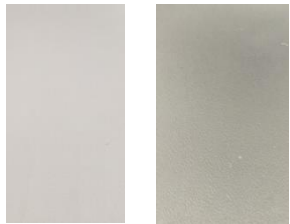

Available colors for metal parts

Gery      Dark Grey





# ITEM NO: ZS-Y101 Folding Chair



Available colors for plastic parts  
White      Black      Beige



Available colors for metal parts  
Beige      Black      White



## Material :

PP Injection molding  
Steel frame Powder coated

· **Packing** : 8pcs/ctn

· **Loading** : 1696pcs/3392pcs/4432pcs  
( 20'GP/40'GP/40'HQ)

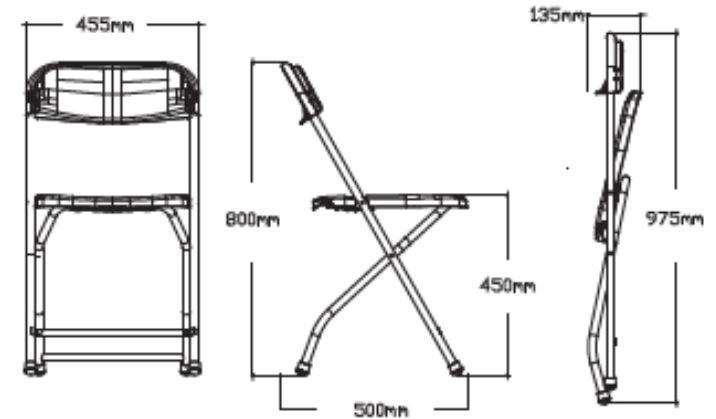

# ITEM NO: ZS-Y101A Folding Chair



Available colors plastic parts

White      Black      Beige



Available color s metal parts

Beige      Black      White



## . Material :

PP Injection molding

Steel frame Powder coated

## . Packing : 8pcs/ctn

## . Loading : 1696pcs/3392pcs/4432pcs ( 20'GP/40'GP/40'HQ)

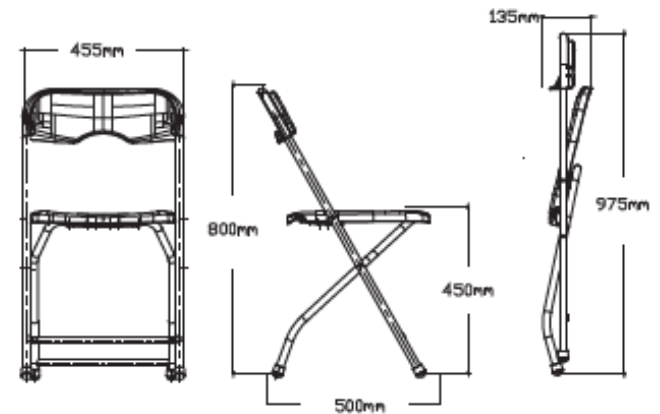

# ITEM NO: ZS-Y101B Folding Chair



Available colors for plastic parts  
White      Black      Beige



Available colors for metal parts  
Beige      Black      White



## . Material :

PP Injection molding  
Steel frame Powder coated

. Packing : 8pcs/ctn

. Loading : 1376pcs/2960pcs/3496pcs  
( 20'GP/40'GP/40'HQ)

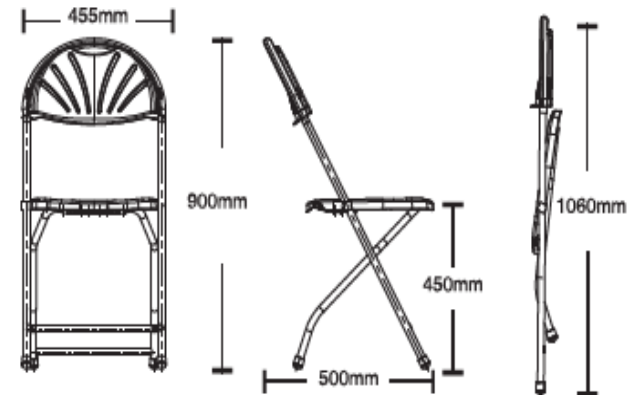

# ITEM NO: ZS-Y102 Folding Chair



Available colors for plastic parts

White    Black



Available colors for metal parts

Grey    Black    White



## . Material :

PP Injection molding

Steel frame Powder coated

## . Packing : 8pcs/ctn

. Loading : 1464pcs/3208pcs/3832pcs  
( 20'GP/40'GP/40'HQ)

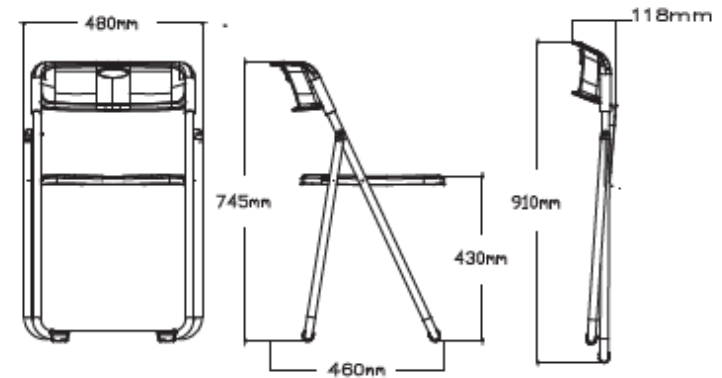

# ITEM NO: ZS-Y103 Folding Chair



Available colors for plastic parts

White      Black



Available colors for metal parts

Black      White



- **Material :**  
PP injection molding  
Steel frame Powder coated
- **Packing :** 5pcs/ctn
- **Loading :** 565pcs/1245pcs/1485pcs  
( 20'GP/40'GP/40'HQ)

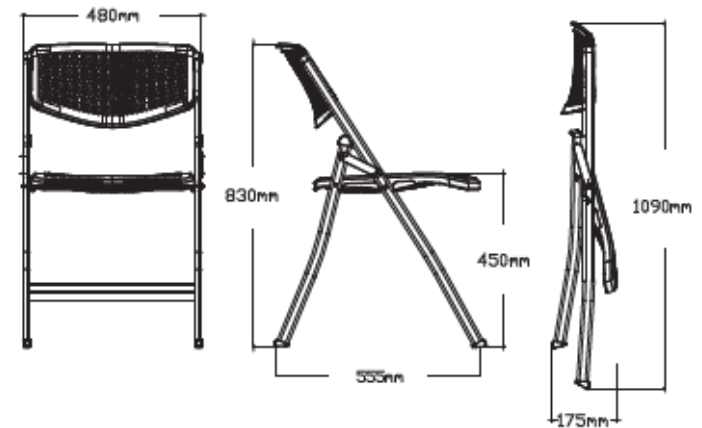

# ITEM NO: ZS-Y104 Folding Chair



Available colors for plastic parts  
White Black

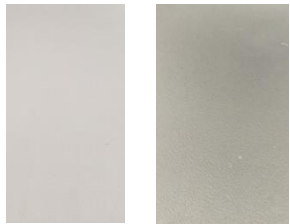

Available colors for metal parts  
Grey Black White



## . Material :

PP injection molding  
Steel frame Powder coated

. Packing : 4pcs/ctn

. Loading : 744pcs/1600pcs/1940pcs  
( 20'GP/40'GP/40'HQ)

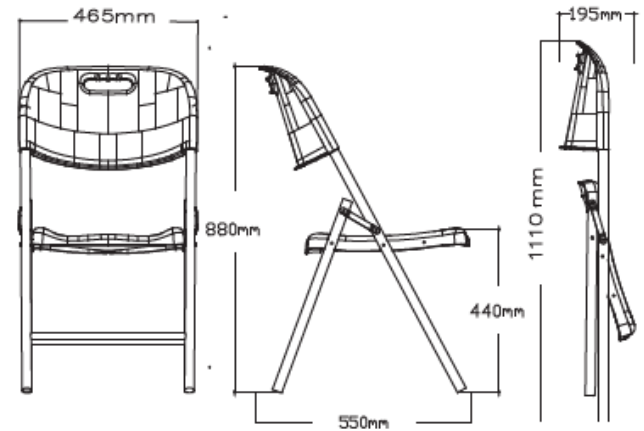

# ITEM NO: ZS-Y105 Folding Chair



Available colors for plastic parts

White Black



Available colors for metal parts

Grey Black White



## . Material :

PP injection molding

Steel frame Powder coated

## . Packing : 5pcs/ctn

. Loading : 650pcs/1400pcs/1700pcs  
( 20'GP/40'GP/40'HQ)

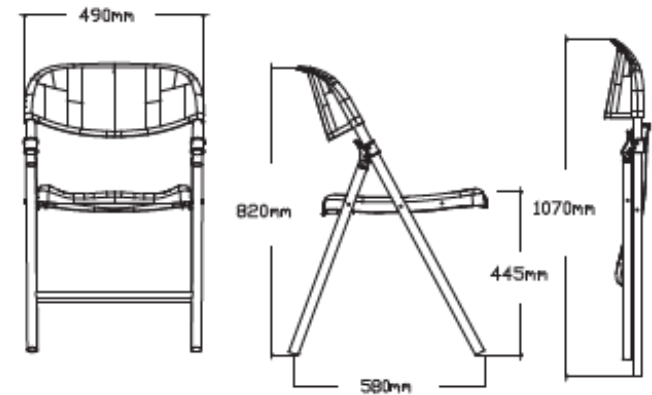

# ITEM NO: ZS-Y106 Plastic stackable Chair



## . Material :

PP Injection molding  
fiber glass added  
Aluminium alloy legs :25\*1.2MM .  
Internal stiffeners

## . Packing : 6 pcs/ctn

## . Loading : 720pcs/1560pcs/18960pcs ( 20'GP/40'GP/40'HQ)

Available colors for plastic parts

White    Black

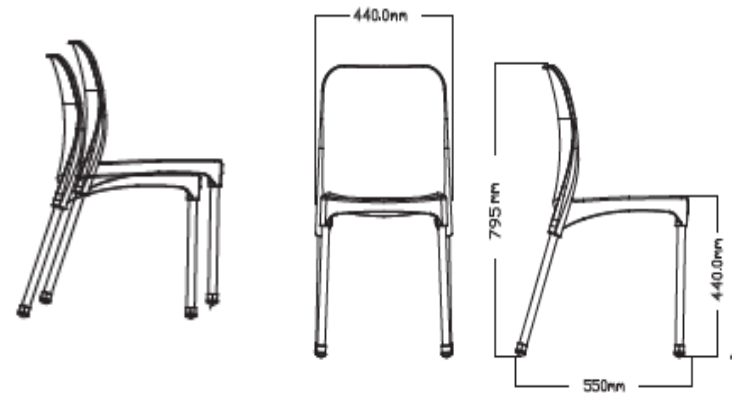
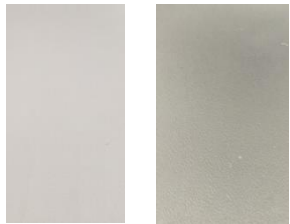



# ITEM NO: ZS-Y107 Folding Chair



Available colors for plastic parts  
White Black



Available colors for metal parts  
Dark Grey



## . Material :

PP Injection molding  
Steel frame Powder coated

. Packing : 6pcs/ctn

. Loading : 1938pcs/4176pcs/4926pcs  
( 20'GP/40'GP/40'HQ)

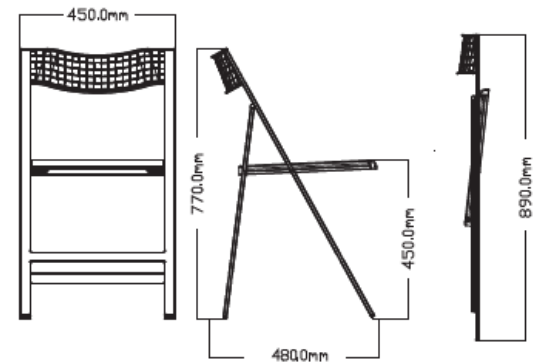

# ITEM NO: ZS-Y108 Folding Stool



- **Material :**  
PP injection molding  
Steel frame Powder coated
- **Packing :** 8pcs/ctn
- **Loading :** 1920pcs/4144pcs/5032pcs  
( 20'GP/40'GP/40'HQ)

Available colors for plastic parts  
White    Black



Available colors for metal parts  
Dark Grey    Black    White

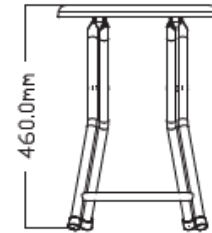

# ITEM NO: ZS-Y109 Folding chair



## Material :

PP injection molding  
Steel frame Powder coated

Packing : 4pcs/ctn

Loading : 672pcs/1400pcs/1648pcs  
( 20'GP/40'GP/40'HQ)

Available colors for plastic parts

White Blue Brown



Available colors for metal parts

Blue Brown White

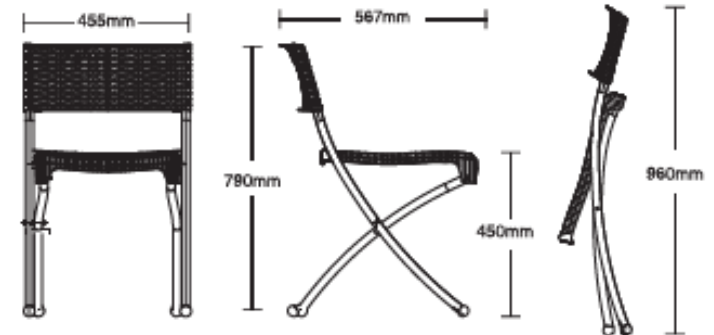

# ITEM NO: ZS-T109 Folding table



Available colors for plastic parts  
White      Blue      Brown

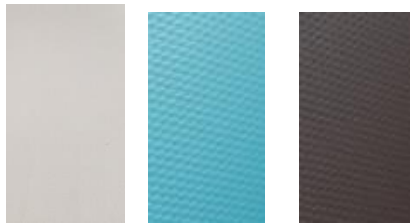

Available colors for metal parts  
Blue      Brown      White



## . Material :

PP injection molding

Steel frame Powder coated

. Packing : 1pc/ctn

. Loading : 320pcs/666pcs/809pcs  
( 20'GP/40'GP/40'HQ)

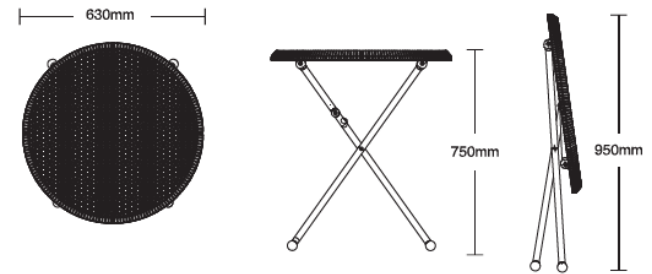

# ITEM NO : ZS-Y502 KIDS Folding Chair



Available colors for plastic parts  
White Red Blue



Available colors for metal parts  
White



- . **Material :**  
PP injection molding  
Steel frame Powder coated
- . **Packing :** 10pcs/ctn
- . **Loading :** 3090pcs/6660pcs/8080pcs  
( 20'GP/40'GP/40'HQ)

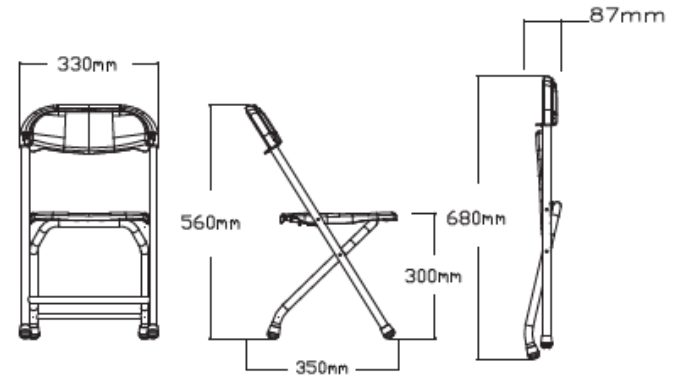

ITEM NO : ZS-Y201

Plastic stackable Chair



**. Material :**

PP injection molding  
fiber glass added

**. Packing :** 5pcs/ctn

**. Loading :** 500pcs/1000pcs/1200pcs  
( 20'GP/40'GP/40'HQ)

Available colors

Grey

Green

Red

Orange

Taupe

White

Sand

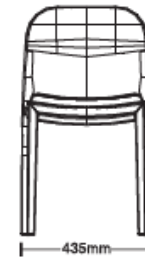
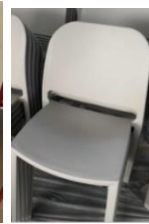

# ITEM NO : ZS-Y203 Plastic folding Chair



- **Material :**  
PP injection molding  
fiber glass added
- **Packing :** 6pcs/ctn
- **Loading :** 1068pcs/2340pcs/2796pcs  
( 20'GP/40'GP/40'HQ)

Available colors  
White

Black

Green

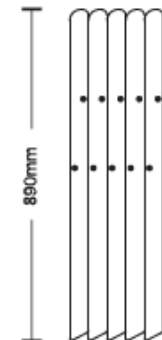
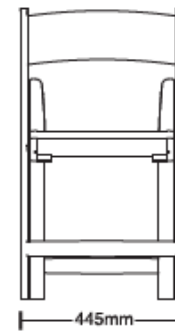
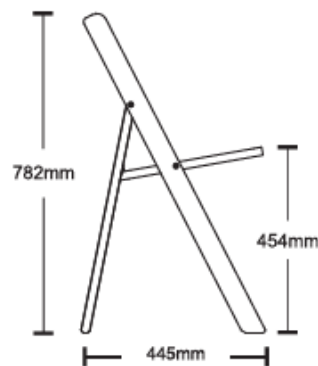

ITEM NO : ZS-Y203A

Plastic folding Chair with soft cushion



**. Material :**

PP injection molding

fiber glass added

Soft cushion : Sponge cover PU leather

**. Packing :** 6pcs/ctn

**. Loading :** 1068pcs/2340pcs/2796pcs  
( 20'GP/40'GP/40'HQ)

Available colors for chair

White

Black

Green



Available colors for chair

White

Black

Beige

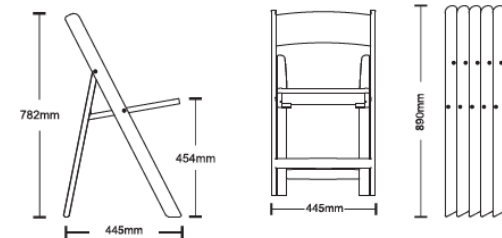
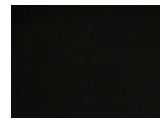
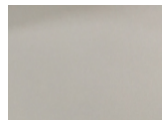



# ITEM NO : ZS-Y203B Plastic folding Chair



## . Material :

PP injection molding  
fiber glass added

. Packing : 6pcs/ctn

. Loading : 1068pcs/2340pcs/2796pcs  
( 20'GP/40'GP/40'HQ)

Available colors  
White

Black

Green

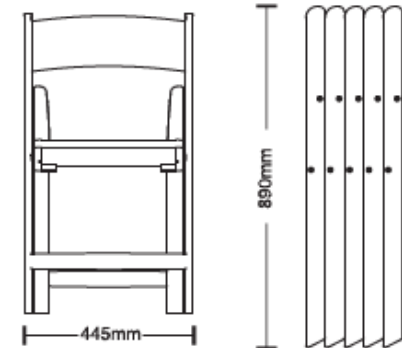
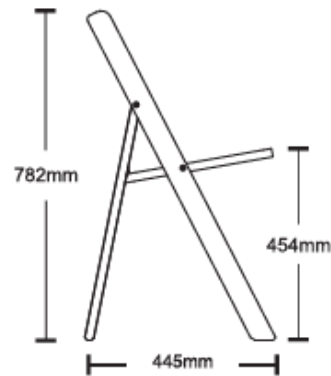

# ITEM NO : ZS-Y204 Plastic stackable Chair



## . Material :

PP injection molding  
fiber glass added

. Packing : 20pcs/Stackaed

. Loading : 500pcs/1000pcs/1250pcs  
( 20'GP/40'GP/40'HQ)

Available colors

Green

Red

Orange

White

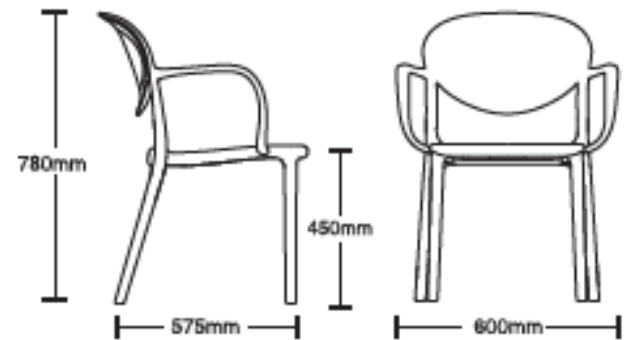
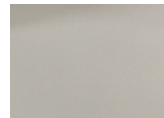

# ITEM NO : ZS-Y205 Plastic folding Chair



## . Material :

PP injection molding  
fiber glass added

. Packing : 6pcs/ctn

. Loading : 750pcs/1650pcs/1872pcs  
( 20'GP/40'GP/40'HQ)

Available colors

White

Black

Green

Orange

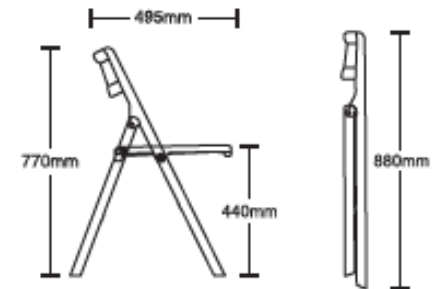

ITEM NO : ZS-Y205A

Plastic folding Chair



**. Material :**

PP injection molding  
fiber glass added

**. Packing :** 6pcs/ctn

**. Loading :** 750pcs/1650pcs/1872pcs  
( 20'GP/40'GP/40'HQ)

Available colors  
White

Black

Green

Orange

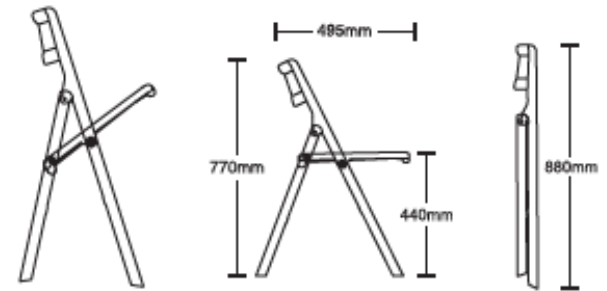

ITEM NO : ZS-Y206

Plastic folding Chair



**Material :**  
PP injection molding  
fiber glass added

**Packing :** 6pcs/ctn

**Loading :** 678pcs/1458pcs/1710pcs  
( 20'GP/40'GP/40'HQ)



Available colors  
White

Green

Orange

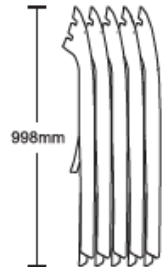
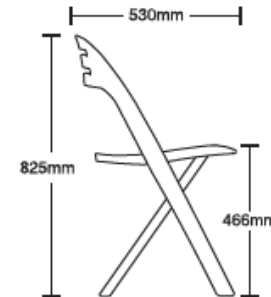

# ITEM NO : ZS-Y207 Plastic folding Chair



## . Material :

PP injection molding  
fiber glass added

. Packing : 4pcs/ctn

. Loading : 440pcs/952pcs/1120pcs  
( 20'GP/40'GP/40'HQ)

Available colors

White

Green

Orange

Black

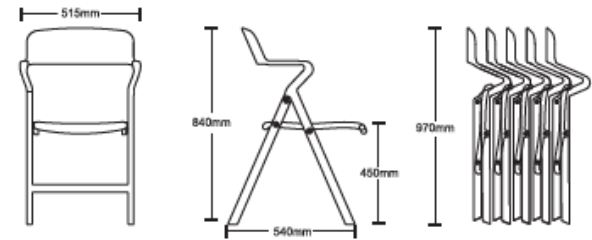
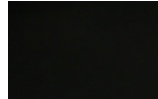
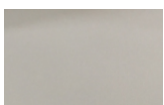

# ITEM NO : ZS-Y208 Plastic folding Chair



## . Material :

PP injection molding  
fiber glass added

. Packing : 6pcs/ctn

. Loading : 624pcs/1344pcs/1584pcs  
( 20'GP/40'GP/40'HQ)

Available colors

White

Black

Green

Orange

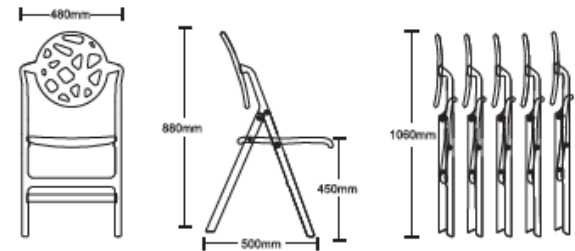

ITEM NO : ZS-Y212

Plastic stackable Chair



**. Material :**

PP injection molding  
fiber glass added

**. Packing :** 5pcs/ctn

**. Loading :** 430pcs/930pcs/1100pcs  
( 20'GP/40'GP/40'HQ)

Available colors

Grey

Green

Red

Orange

Taupe

White

Sand

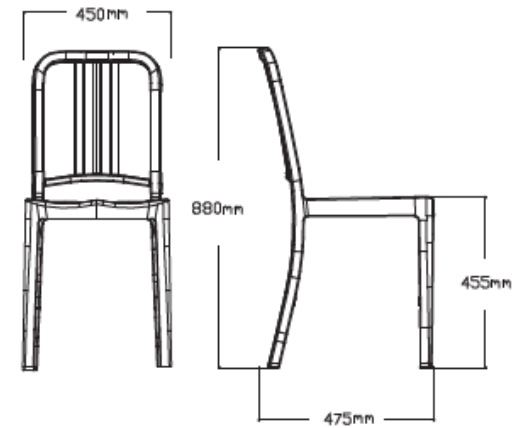
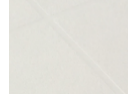



ITEM NO : ZS-Y213

Plastic stackable stool ( For bathroom)



**. Material :**

PP injection molding  
fiber glass added

**. Packing :** 24pcs/ctn

**. Loading :** 1824pcs/3936pcs/4656pcs  
( 20'GP/40'GP/40'HQ)

Available colors

Red

Orange

White

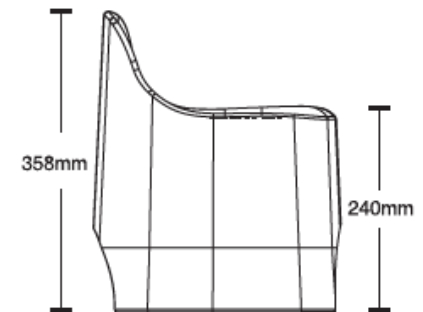
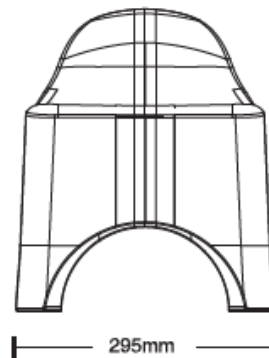
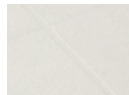

# (Our Dedication)



We have always been dedicated to environment protection and injection of culture connotation, strengthening our brand influence. We will also keep on promoting optimization grouping of production factors and gradually improve modern corporate system. We will continue to serve our customers with strict control, top quality, as well as faithful operation.

